

Power System Monitoring based on (Binary) Relay and Circuit Breaker Information

Christoforos Hadjicostis
ECE, UIUC

George Verghese
EECS, MIT

Sponsored by the Electric Power Research Institute and the US Department of Defense
(Initiative on *Complex Interactive Networks and Systems*)

TALK OUTLINE

- Monitoring discrete event systems
- Petri net modeling of line failures
- Failure detection and identification
- Conclusions and future work

MONITORING DISCRETE EVENT SYSTEMS

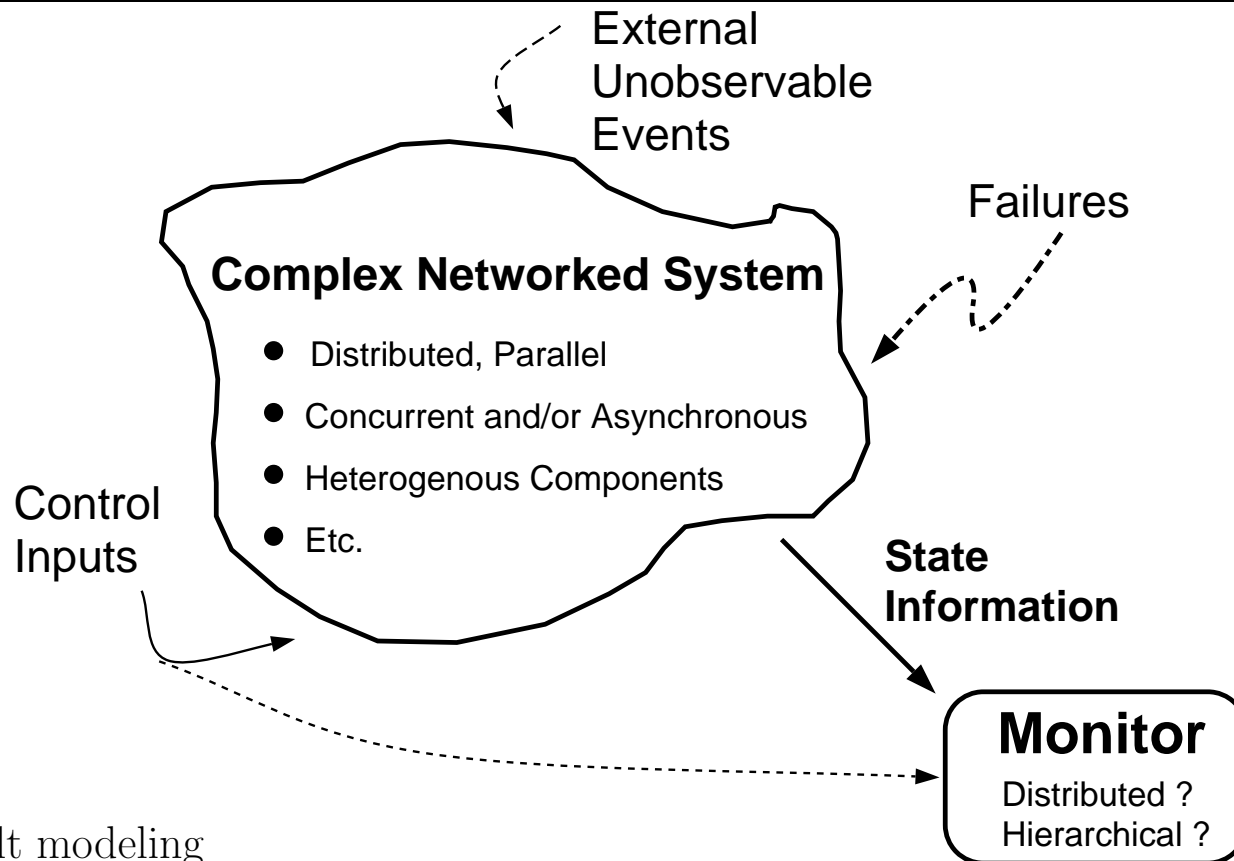

Issues:

- Fault modeling
- Communication cost, monitoring complexity
- Fault coverage, identification algorithm
- Examples: Power systems, manufacturing systems, networked processors, etc.

DESIRABLE FEATURES

Monitor design:

- Simplicity ✓
- Fault coverage, systematic failure identification ✓
- Robustness to erroneous/missing information ✓

Optimality Criteria:

- Minimal communication cost, hardware overhead ×

Other Considerations:

- Distributed and/or hierarchical ×
- Concurrent v.s. non-concurrent ×

PETRI NET MODELS

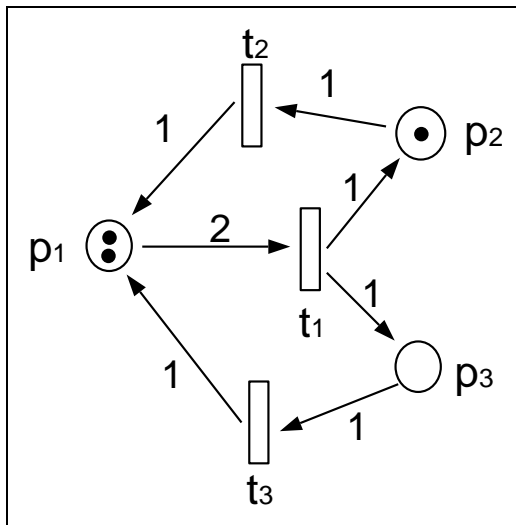

If transition t_1 “fires”:

$$\mathbf{q}[k+1] = \underbrace{\begin{bmatrix} 2 \\ 1 \\ 0 \end{bmatrix}}_{\text{“state } \mathbf{q}[k]\text{”}} + \underbrace{\begin{bmatrix} 0 \\ 1 \\ 1 \end{bmatrix}}_{\text{“postconditions”}} - \underbrace{\begin{bmatrix} 2 \\ 0 \\ 0 \end{bmatrix}}_{\text{“preconditions”}}$$

$$\mathbf{B}^+ = \begin{bmatrix} 0 & 1 & 1 \\ 1 & 0 & 0 \\ 1 & 0 & 0 \end{bmatrix} \quad \mathbf{B}^- = \begin{bmatrix} 2 & 0 & 0 \\ 0 & 1 & 0 \\ 0 & 0 & 1 \end{bmatrix} \quad \mathbf{x}[k] = \begin{bmatrix} 1 \\ 0 \\ 0 \end{bmatrix}$$

“State Evolution”:
$$\mathbf{q}[k+1] = \mathbf{q}[k] + \underbrace{(\mathbf{B}^+ - \mathbf{B}^-)}_{\mathbf{B}} \mathbf{x}[k]$$

Interpretation depends on underlying DES:

- *Tokens*: System resources, acknowledgments, packets
- *Places*: Buffers, storage locations, preconditions, postconditions
- *Transitions*: Events, actions, processors, servers, machinery

CONCURRENT MONITORING USING LINEAR CHECKS

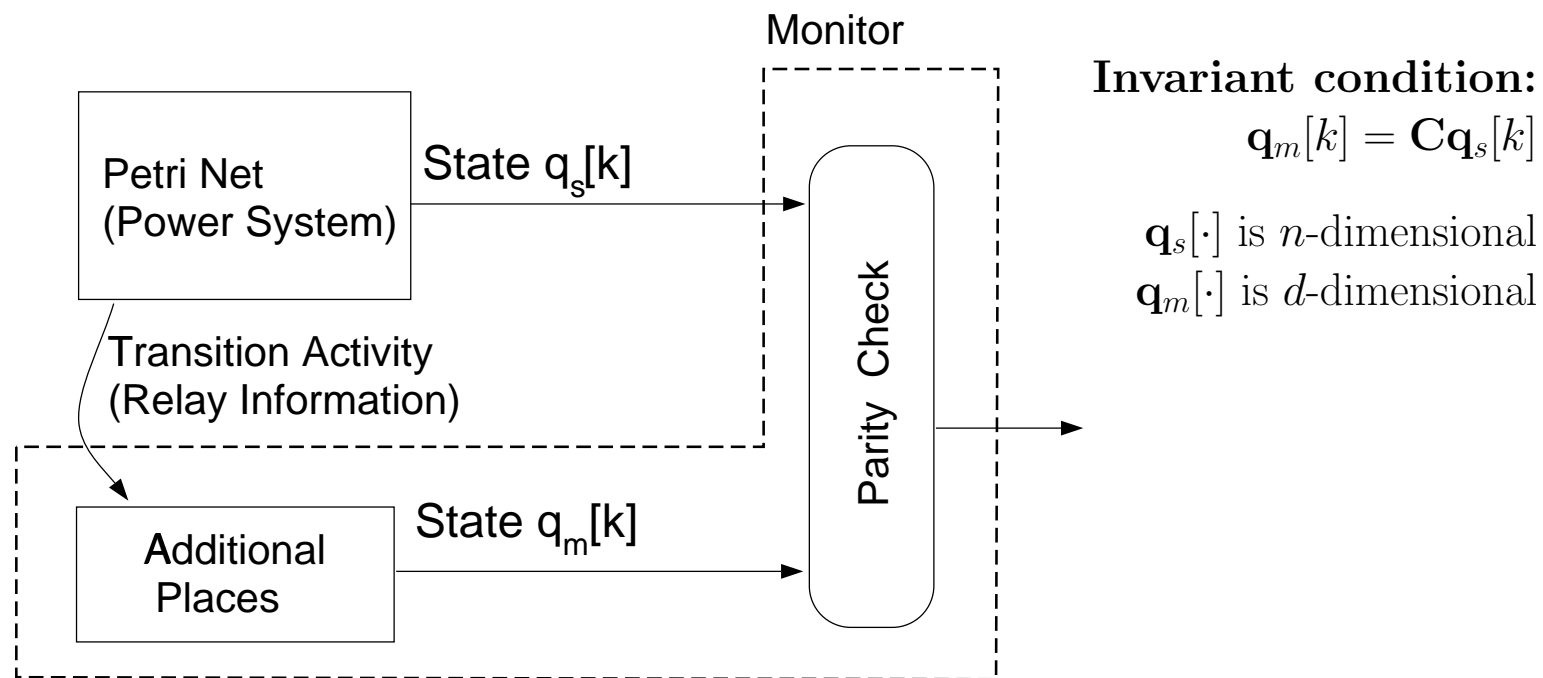

- State evolution of embedding: $\mathbf{q}_h[k+1] = \mathbf{q}_h[k] + \begin{bmatrix} \mathbf{B} \\ \mathbf{CB} \end{bmatrix} \mathbf{x}[k]$

where $\mathbf{q}_h[k] = \begin{bmatrix} \mathbf{q}_s[k] \\ \mathbf{q}_m[k] \end{bmatrix}$

- Parity check: $\underbrace{\begin{bmatrix} -\mathbf{C} & \mathbf{I}_d \end{bmatrix}}_{\mathbf{P}} \mathbf{q}_h[k] \stackrel{?}{=} \mathbf{0}$

SYNDROME-BASED DETECTION AND IDENTIFICATION OF FAILURES

- **Additive error model:** $\mathbf{q}_f[k] = \mathbf{q}_h[k] + \mathbf{e}_f$
where $\mathbf{q}_h[k]$ is the fault-free state

- **Parity check / Syndrome generation:**

$$\mathbf{s}[k] = \underbrace{\begin{bmatrix} -\mathbf{C} & \mathbf{I}_d \end{bmatrix}}_{\mathbf{P}} \mathbf{q}_f[k] = \mathbf{P}\mathbf{e}_f$$

- **Single Error Detection:** Choose \mathbf{C} so that syndromes are non-zero
- **Single Error Identification:** Choose \mathbf{C} so that syndromes are unique
- **Multiple Errors:** Applications of linear algebra and coding theory

PETRI NET MODELING OF LINE FAILURES

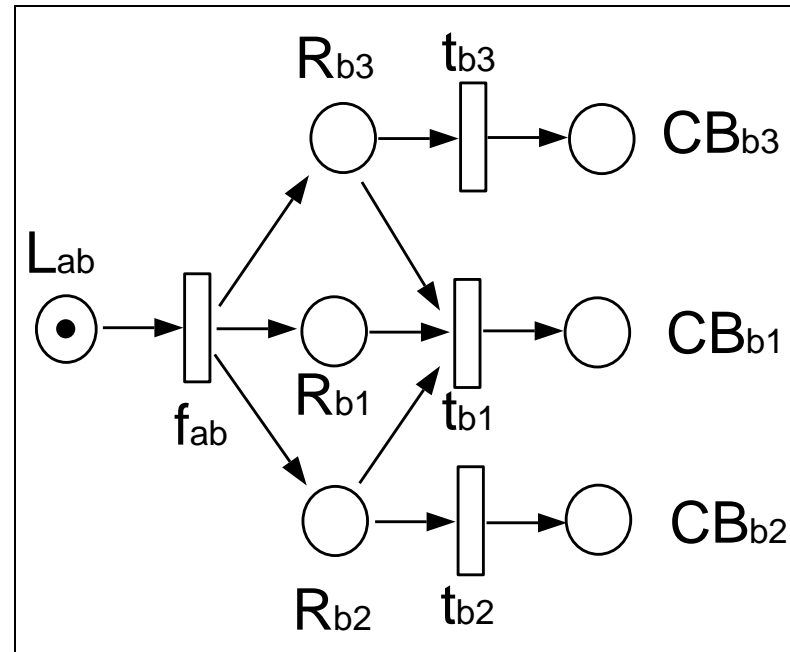
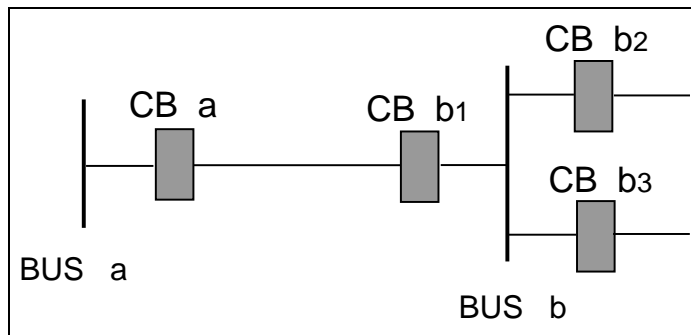

- Transition f_{ab} models failure in line $a-b$
- Primary protection: Relay R_{b1} and circuit breaker CB_{b1}
- Secondary protection: Relays R_{b2} , R_{b3} and circuit breakers CB_{b2} , CB_{b3}

PETRI NET MODELING OF LINE FAILURES (2)

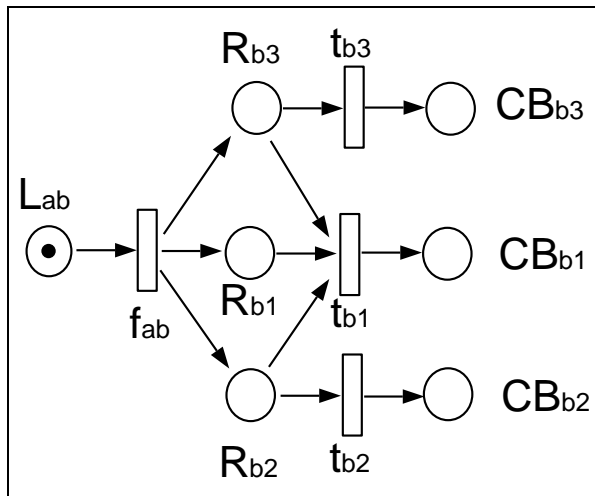

$$\mathbf{q}_s[k+1] \equiv \begin{bmatrix} L_{ab}[k+1] \\ R_{b_1}[k+1] \\ R_{b_2}[k+1] \\ R_{b_3}[k+1] \\ CB_{b_1}[k+1] \\ CB_{b_2}[k+1] \\ CB_{b_3}[k+1] \end{bmatrix} = \mathbf{q}_s[k] + \underbrace{\begin{bmatrix} -1 & 0 & 0 & 0 \\ 1 & -1 & 0 & 0 \\ 1 & -1 & -1 & 0 \\ 1 & -1 & 0 & -1 \\ 0 & 1 & 0 & 0 \\ 0 & 0 & 1 & 0 \\ 0 & 0 & 0 & 1 \end{bmatrix}}_{\mathbf{B}} \mathbf{x}[k]$$

Monitor does NOT have access to:

- Transition f_{ab}
- Places L_{ab} and R_{b_1} , R_{b_2} , R_{b_3}

IMPLICATIONS TO MONITOR DESIGN

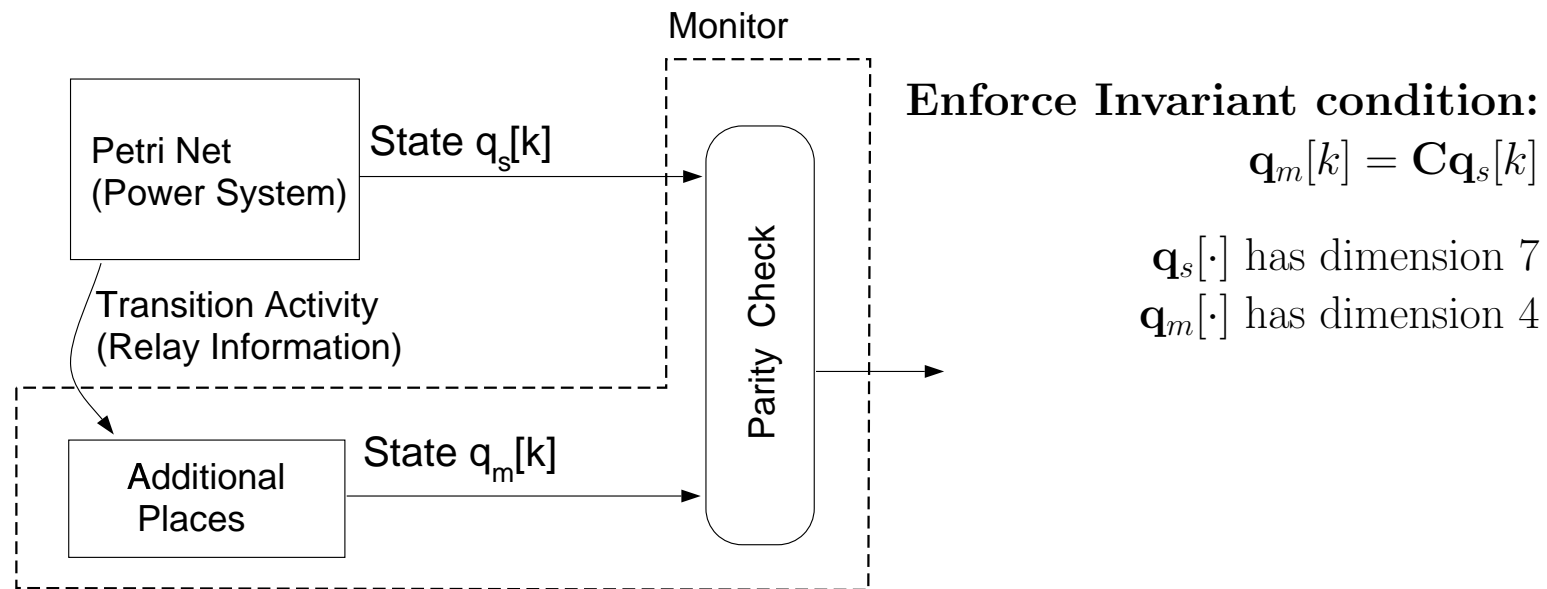

- No transition information from f_{ab} implies $\mathbf{CB}(:, 1) = \mathbf{0}$
- Unique syndrome $\mathbf{s}[k] = \begin{bmatrix} -\mathbf{C} & \mathbf{I}_4 \end{bmatrix} \mathbf{e}_f$ for each combination of failures
- \mathbf{e}_f needs to be specified for different failures f

MONITOR DESIGN

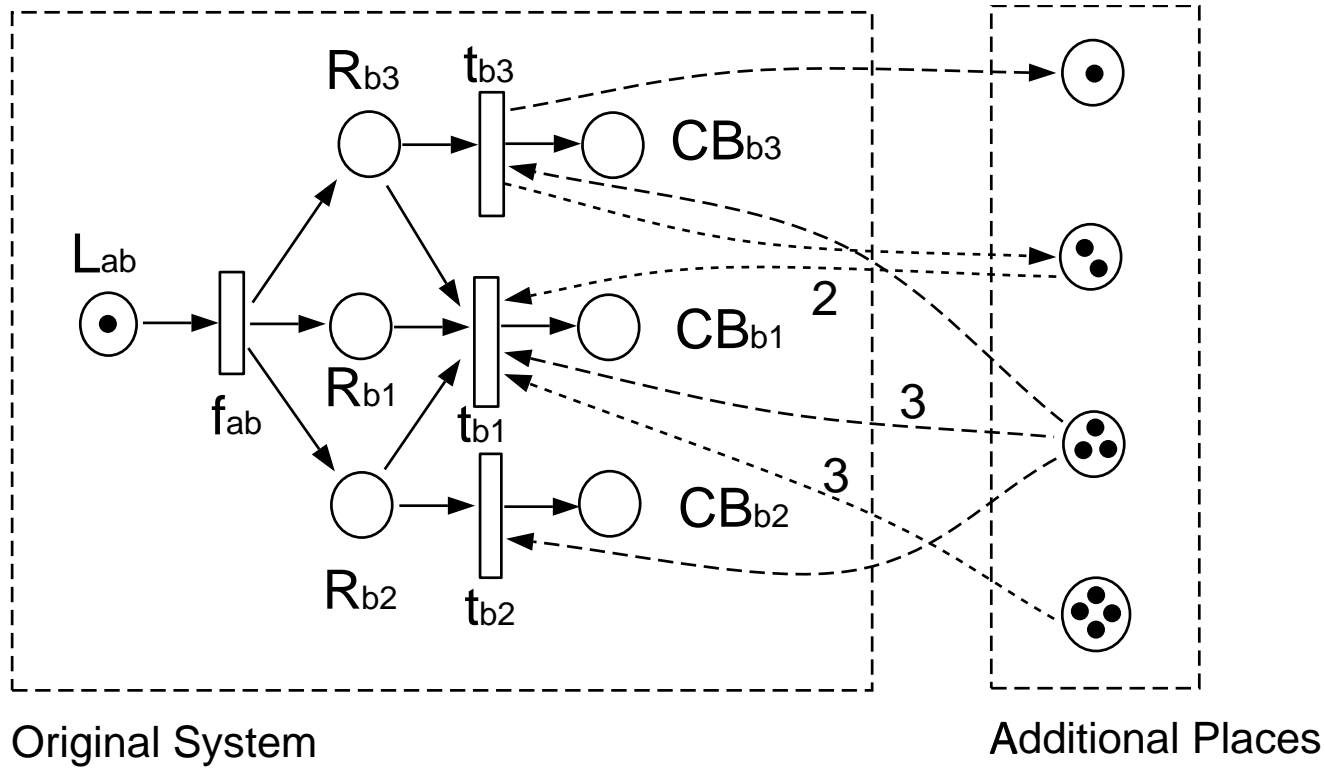

$$C = \begin{bmatrix} 1 & 1 & 0 & 0 & 1 & 0 & 1 \\ 2 & 1 & 1 & 0 & 0 & 1 & 1 \\ 3 & 1 & 1 & 1 & 0 & 0 & 0 \\ 4 & 2 & 1 & 1 & 1 & 1 & 1 \end{bmatrix},$$

$$CB = \begin{bmatrix} 0 & 0 & 0 & 1 \\ 0 & -2 & 0 & 1 \\ 0 & -3 & -1 & -1 \\ 0 & -3 & 0 & 0 \end{bmatrix}$$

SYNDROMES FOR DIFFERENT FAILURES

1. **Line Failure** f_{ab} :

$$\text{Faulty State: } \mathbf{q}_{f_{ab}}[k] = \mathbf{q}_h[k] + \mathbf{e}_1$$

$$\text{Syndrome: } \mathbf{s}_{f_{ab}}[k] = \mathbf{P}\mathbf{q}_{f_{ab}}[k] = -\mathbf{C}(:, 1)$$

2. **Misfiring of Circuit Breakers** f_{b_j} :

$$\text{Faulty State: } \mathbf{q}_{f_{b_j}}[k] = \mathbf{q}_h[k] + \begin{bmatrix} \mathbf{0} \\ \mathbf{CB} \end{bmatrix} \mathbf{x}_{tb_j} - \mathbf{e}_{R_{b_j}}$$

$$\text{Syndrome: } \mathbf{s}_{f_{b_j}}[k] = \mathbf{P}\mathbf{q}_{f_{b_j}}[k] = (\mathbf{CB})(:, j + 1) + \mathbf{C}(:, j + 1)$$

3. **Erroneous/Missing Reports from Circuit Breakers** $f_{CB_{b_i}}$:

$$\text{Faulty State: } \mathbf{q}_{f_{CB_{b_i}}}[k] = \mathbf{q}_h[k] \pm \mathbf{e}_{CB_{b_i}}$$

$$\text{Syndrome: } \mathbf{s}_{CB_{b_i}}[k] = \mathbf{P}\mathbf{q}_f[k] = \mp \mathbf{C}(:, i + 4)$$

CONCLUSIONS

Power System Monitoring Schemes:

- Systematic identification, simple design
- Automatic recognition of necessary acknowledgments and communication links
- Robustness to information losses due to communication failures
- Connections with linear algebra and coding

Future work:

- Minimize connections, communication cost, monitor size, etc.
- Hierarchical and/or distributed schemes
- Applications to manufacturing systems, communication protocols
- Error recovery